



EasyKart EGYPT

SPORTING & TECHNICAL REGULATION 25

SPORTING REGULATIONS 2025 -----	3
Art. S1) Promoter -----	3
Art. S2) General sporting rules -----	3
Art. S3) Trophy -----	3
Art. S4) Licenses -----	4
Art. S5) Race numbers -----	4
Art. S6) Permitted drivers -----	5
Art. S7) Registration -----	5
Art. S8) Fees -----	6
Art. S9) Karts allowed -----	6
Art. S10) Tyres -----	6
Art. S11) Pre-race checks -----	7
Art. S12) Briefing -----	7
Art. S13) Sport conduct -----	8
Art. S14) Race regulations -----	8
Art. S15) Starting procedure -----	8
Art. S16) Warm-ups, qualifying practice and sprint race -----	9
Art. S17) Finals -----	9
Art. S18) Stopping a race and the starting procedures -----	10
Art. S19) Wet Race -----	10
Art. S20) Penalty for non-compliant front spoiler position -----	10
Art. S21) Technical Checks -----	10
Art. S22) Protests and Appeals -----	11
Art. S23) Rankings and scores -----	12
Art. S24) International Grand Final -----	13
Art. S25) Advertising -----	13
Art. S26) Awards -----	13
Art. S27) Other provisions -----	14
EasyKart TECHNICAL REGULATIONS -----	15
Art. T1) General technical regulations -----	15
Art. T2) Chassis -----	15
Art. T3) Engine -----	23
Art. T4) Fuel -----	26
Art. T5) Transmission -----	27
Art. T6) Tyres -----	27
Art. T7) WEIGHT -----	28
TECHNICAL REGULATIONS BMB CHALLENGE 2025 -----	29
Art. T1) GENERAL RULES -----	29



Art. T2) Chassis-----	29
Art. T3) Engine-----	29
Art. T4) Fuel-----	30
Art. T5) Tyres-----	30
Art. T6) WEIGHT-----	31
TECHNICAL REGULATIONS TM KART CHALLENGE 2025-----	32
Art. T1) General rules-----	32
Art. T2) Chassis-----	32
Art. T3) Engine-----	32
Art. T4) Fuel-----	33
Art. T5) Tyres-----	34
Art. T6) WEIGHT-----	34
Appendix -----	35
Art. G1) APPENDIX 1-CALENDAR 2025-----	35
Art. G2) APPENDIX 2 - Flags & Boards-----	36
Art. G3) APPENDIX 3 -Pricing and Detail-----	38



EasyKart Trophy - Egypt

SPORTING REGULATIONS 2025

Art. S1) Promoter

- S1.1) Birelart Egypt – Kart Riders, hereinafter referred to as the “Promoter”, license number 228434, with registered office in F0-5 Agora Commercial Complex telephone 01066554544 – email EasyKarttrophy@kartriders-eg.com, announces and promotes the EasyKart Egypt TROPHY (hereinafter referred to as “Trophy”)
- S1.2) For each event, the Promoter may identify and delegate its own representative who will have a supporting role in addition to carrying out any activity useful for the best outcome of the event.
- S1.3) For anything not specified in these sporting regulations, the Specific Karting Sporting Regulations, the National Sporting Regulations, and the International Karting Regulations will be referred to. Any appendices and/or changes to these Regulations must be approved by ATCE ASN and will become an integral part thereof with effect from the day of publication on the official Trophy website.

Art. S2) General sporting rules

- S2.1) The races will take place on one or more days, according to the format indicated in the following articles S16 and S17, indicated in the approved Specific Race Regulations.
- S2.2) The organization of the individual races of the Trophy will comply with the ATCE ASN sport regulations in force for Brand Trophy competitions. However, it remains the responsibility of the individual organizers to provide adequate staff according to the number of drivers expected.
- S2.3) The categories admitted to the Trophy will be: EasyKart 60 – EasyKart 100 – EasyKart 125 EasyKart 125 Senior (EasyKart 125 subcategory) – BMB Challenge – TM KART Challenge.
- S2.4) The Trophy will be divided into several races, as per the official calendar attached to these regulations.

Art. S3) Trophy

- S3.1) The Trophy will include multiple races that will take place on a single day, except for any exceptions due to the special needs of the organizer.
- S3.2) The winner will be nominated by adding the scores obtained in each race, as described in art. S23. For the purposes of the final rankings of the Trophy, it will be mandatory to “discard” the worst result (also non-



participation of a round); **it is specified that** it will not be possible to discard any disqualifications.

Art. S4) Licenses

- S4.1) The following will be admitted to the Trophy races: competitors and drivers, in accordance with the provisions of Art. 6 of the Specific Karting Sporting Regulations and with the Brand Trophy Regulations, in possession of an Egyptian ASN karting license; foreign competitors and drivers in possession of international karting or national karting license accompanied by the authorization of their own ASN (if the event is defined as National with Authorized Foreign Participation – NEAFP). Competitors and drivers with an international “A” karting license are not allowed.
- S4.2) It is the Promoter's right to invite professional drivers to the events on a promotional basis, even if they have an international “A” license. These competitors will not be considered for the purposes of the rankings.
- S4.3) In the case of underage drivers, the provisions of the current Specific Karting Sporting Regulations apply.
- S4.4) During sporting checks, all licenses must be accompanied by the original copy of the medical certificate of fitness for competitive karting activities, issued by a sports medicine center, the ATCE ASN card, and the mechanical assistant license for the person who can access the Parc fermé.
- S4.5) In the case of underage drivers, registered by a Legal Person competitor, the authorization of the parents and/or those exercising parental authority must also be presented, and duly completed.

Art. S5) Race numbers

- S5.1) The race numbers are assigned by the Promoter, who will coordinate the EasyKart sports activity. The number will be assigned directly by the promoter depending on the category to which the driver belongs. The number is valid for one year and must remain the same in all official races.
- S5.2) The race number must be applied on yellow boards, positioned as follows: one on the front, one on the back, and two on the sides (right and left). The number must be black and it must always be legible.
- S5.3) The first three (3) is reserved for the winners of the previous year's Trophy.
If the winners prefer not to use these numbers, they will not be assigned.
- S5.4) The race numbers are assigned as follows:
EasyKart 60 (100-199), EasyKart 100 (200-299), EasyKart 125 (300-399), BMB Challenge (400-499), and TM Kart Challenge (500-599).



Art. S6) Permitted drivers

S6.1) The following drivers with ATCE licenses are allowed:

EasyKart 60	Lic. National MINI
Easykart 100*	Lic. National MINI, National G, International G, National F, International F, National E , International E From 12 years of age during the year
Easykart 125	Lic. National F, International F, National E, International E From 14 years of age during the year
BMB Challenge	Lic. National G, International G, National F, International F, National E, International E From 14 years of age during the year
TM KART Challenge R2	Lic. National E, International E From 15 years of age during the year

*From 11 years of age, provided that they present a competitive medical certificate attesting to a weight (including equipment) of at least 35 kg at all times during the competition.

S6.2) If indicated in the Specific Race Regulations, the Trophy races will allow the participation of foreign drivers, as indicated in point S4.1.

S6.3) On the same day of the race, each driver will be able to compete **in one category only.**

Art. S7) Registration

S7.1) The registration form, which also includes the self-certification form for pre-race sporting and technical checks, will be delivered by the organizer at the time of the administrative completion of the registrations themselves.

S7.2) The individual Organizers have the right to organize a limited number of events.

S7.3) The promoter reserves the right not to accept the registration of a competitor-driver to one or more races of the Trophy itself, according to the methods and terms provided for by the National Sporting Regulations.



Art. S8) Fees

- S8.1) The registration fee for the EasyKart Trophy Egypt that take place in Curve karting RSTC amounts to EGP 10,000 VAT Excluded; the fee for the free trials on the day before the race amounts to EGP 2,000 VAT Excluded. The registration fee and the fee for the free trials on the days before the races may vary for some trials of the Trophy where specified in the Appendix 3

Art. S9) Karts allowed

- S9.1) The karts described in the technical regulations can participate in the Trophy races.
- S9.2) In the EasyKart 60, EasyKart 100, and EasyKart 125 categories it will be possible to register only one (1) chassis and two (2) engines, while in the BMB Challenge & TM KART Challenge categories it will be possible to register up to two (2) chassis of the same brand and two (2) engines, both to be indicated in the self-certification to be delivered in Parc fermé before the start of qualification.

It is forbidden to replace the engines or chassis declared in the self-certification form during the event.

- S9.3) For the EasyKart 60, EasyKart 100, and EasyKart 125 categories, in case of non-repairable breakage of the chassis, the competitor is allowed to replace it. For all categories, in the event of non-repairable engine breakage, the competitor is allowed to replace it only if authorized by the Stewards. These circumstances will result in a retreat of 5 positions on the starting grid of the next race, regardless of whether it is a heat, sprint race, or final.

Art. S10) Tyres

- S10.1) All categories of the Trophy will use the "slick" and/or "rain" tyres described in the technical regulations.
- S10.2) On the occasion of the Trophy events, new tyres will be distributed by drawing lots and for a fee directly by the Promoter or by a single authorized distributor and checked with the Parc fermé method in compliance with the provisions of the Specific Karting Sporting Regulations.
- S10.3) For each single round, only one new set of "slick" tyres (2 front + 2 rear) collected in Parc fermé must be used; the promoter has the right to provide for the use of additional tyres, if necessary, after notifying all participating drivers; they must be mounted by the mechanical assistant, indicated in the self-certification form, and/or by the competitor/driver strictly at the times established in the official schedule. Only for the BMB CHALLENGE & TM KART Challenge, the use of a 5th tyre will be allowed during the official day of the race at the



discretion of the driver. It will be possible to decide whether to use the 5th tyre (front or rear) at any time of the official day of the race to be collected and fitted in Parc fermé after purchasing the voucher at the kart riders facility on the track. It should be noted that the purchase of the 5th tyre is optional.

- S10.4) If a tyre breaks or is verified as faulty during the event, the Stewards (upon the written request of the technical delegate) may authorize the purchase and replacement of the tyre with a new one or a used tyre of similar consumption.
- S10.5) During warm-ups, it will not be possible to use the set of race tyres deposited in the Parc fermé.
- S10.6) On the occasion of events not included in the Trophy, the promoter may authorise the use of "slick" and/or "rain" tyres (new or used at the discretion of the competitor-driver) which, at the discretion of the Technical Commissioners, may be deposited in the Parc fermé and/or "punched" at the end of the qualifying practice session.
- S10.7) In the case of a "WET RACE", it will be possible to use only one set (2 front + 2 rear) of "rain" tyres (new or used at the discretion of the competitor-driver), which be deposited in the Parc fermé at the end of the first race session in which they are used.
- S10.8) In the case of a "WET RACE", for safety reasons, the Stewards may make any changes to the restrictions imposed on the use of "rain" tyres, authorising the use of one or more additional sets.

Art. S11) Pre-race checks

- S11.1) At the time of the sporting checks, it is mandatory to present the ATCE ASN sports license of the competitor and driver, the original copy of the medical certificate of fitness for competitive karting/motor racing activities, issued by a sports medicine center, the ATCE ASN card (for adults) and the mechanical assistant promoter accreditation certificate for the person who is allowed to access the Parc fermé and all other documents necessary and required by the National Sporting Regulations. Each verified driver may be assisted in the Parc fermé only by a single mechanic accredited by the promoter. The same must be indicated in the self-certification form presented by the competitor during the sporting checks.

Art. S12) Briefing

- S12.1) For each event of the Trophy, a briefing will be held by the Race Director, who will inform the participants about the Specific Race Regulations, specifying the terms of the starting procedure, the qualifications, the areas where it is allowed to intervene on the vehicles and the meaning of the flag signals used. It is mandatory to attend the briefing.



S12.2) Alternatively, the Race Director may deliver a written briefing to the drivers or it may be published on the official race website.

Art. S13) Sport conduct

S13.1) All people involved in the Trophy in any way are obliged to behave in accordance with the principles of courtesy and mutual respect for the entire duration of the event.

S13.2) The drivers and their companions are obliged to maintain exemplary behavior during the event aimed at reducing dangerous situations, complying with all the provisions of the regulations, the Race Management, and the flags displayed.

S13.3) It is forbidden for all competitors and drivers to start the engines in any area of the track and paddock as from the moment technical control has finished. Any infringement will be subject to the measures provided for by the Promoter.

Art. S14) Race regulations

S14.1) The track must be traveled exclusively in the direction decided when the Specific Race Regulations were approved.

S14.2) The route must be followed in its entirety. If a route is cut, for whatever reason, and this action results in an advantage in terms of ranking position or reduction of the expected distance, measures shall be taken by the Stewards which, depending on the severity of the violation, can lead to exclusion.

S14.3) In the event that a kart stops on the track for any reason, both during the race and during the practice sessions, the driver must take the vehicle to the edge of the track out of the way and get back on the track only after making sure that no other drivers are coming.

S14.4) Any repairs during the races must only be carried out in the repair area.

Art. S15) Starting procedure

S15.1) All categories will follow the rolling start procedure; see the provisions of the Specific Karting Sporting Regulations. The EasyKart starts in Rolling Start. Overtaking can only begin after the karts have crossed the Yellow line. For the category TM KARTChallenge it will be a standing start procedure as art. 2.20a (2025 Fia Karting General Prescriptions).

S15.2) It is forbidden to use the starter on the track. In case of failure to start, one or more people delegated by the promotor are allowed to retrieve the starter made available by the promotor, which will be outside the pre-grid, and start the kart only after all the field has left the pre-grid, or if the start is on the track that all other karts have passed the start line. The delayed driver will be able to get back to his/her position during the formation lap up to the red line.



- S15.3) When required, the Race Director and the Stewards may also have a video recording system both in the starting area and in other areas of the circuit.

Art. S16) Warm-ups, qualifying practice and sprint race

- S16.1) See the provisions of the Specific Karting Sporting Regulations.
- S16.2) Warm-ups session will be 10 minutes, Qualifying practice will take place according to the Karting Sporting Regulations. qualifying practice will be held in a single session lasting 6 minutes.
- S16.3) Penalties will be attributed in the qualifying practice and in the sprint race according to the following criterion: 1st place will be assigned 0 (zero) penalties, 2nd place will be assigned 2 (two), 3rd place will be assigned 3 (three) and so on, gradually increasing by 1 (one). In case of disqualification, exclusion or cancellation of the times, as many penalties as the number of participants plus 1 (one) will be assigned. In the event that more than one driver goes off track simultaneously during the sprint race, before the end of the first lap, the time taken in the qualifying practice will be considered valid for the purposes of the rankings.
- S16.4) In the event that the number of verified drivers exceeds the maximum capacity of the track, the Stewards will:
- For qualifying practice, divide them into one or more groups by drawing lots. Then, a single ranking will be drawn up;
 - For the sprint race, they will be divided according to the order of succession of the overall qualifying practice ranking: 1st place in sprint race "A", 2nd place in sprint race "B", 3rd place in sprint race "A", 4th place in sprint race "B", ...

For the purposes of the penalty ranking, the penalties will be attributed based on the results obtained in the qualifying practice and in the sprint race.

- S16.5) In the event that a competitor is found to be non-compliant at the end of the qualifying practice and/or the sprint race, he/she will be subject to the provisions of the international Sporting regulations.

Art. S17) Finals

- S17.1) The starting grid of the final will be determined by the sum of the penalties of the qualifying practice and the sprint race. In the case of equality, the best time obtained during the qualifying practice will be considered valid.
- S17.2) The EasyKart Trophy races must provide for a single final with a distance that complies with what is set out by the Karting Sporting Regulations



- S17.3) The Stewards, in the event of force majeure dictated by reasons of safety and necessity, will have the right to change the number of laps provided for in the Specific Race Regulations.
- S17.4) In the event that the number of verified drivers is equal to or less than the capacity of the track, after the qualification phase (qualifying practice and sprint race), the drivers will compete in a single final "A". In the event that the number of verified drivers is greater than the capacity of the track, after the qualification phase (qualifying practice and sprint race), a number of drivers equal to the capacity of the track minus five (5) will access the final "A" and/or "B" and/or "C" etc. The first five (5) positions in the "D" and/or "C" and/or "B" finals will earn the right to participate in the Grand Final.
- S17.5) The winner will be the driver who has covered the expected distance (expressed in laps) in the shortest time. All the other drivers will follow in the ranking according to the distance accumulated by the winner.

Art. S18) Stopping a race and the starting procedures

- S18.1) See the provisions of the Specific Karting International Sporting Regulations.

Art. S19) Wet Race

- S19.1) See the provisions of the Specific Karting International Sporting Regulations.

Art. S20) Penalty for non-compliant front spoiler position

- S20.1) For all EasyKart Trophy categories, the detachable front spoiler rule applies; see the provisions of the Specific Karting International Sporting Regulations in force. With 5-second penalty.

Art. S21) Technical Checks

- S21.1) At the end of all official races and qualifications, karts must undergo the overall weight control procedure.
- S21.2) After the weighing procedure, the karts must remain in the Parc fermé area. Only after the time provided for by the Specific Karting Sporting Regulations will the vehicles be able to leave the Parc fermé according to the express instructions of the Stewards.
- S21.3) The Stewards, at any time of the event and at their discretion, may arrange technical checks referring to the technical regulations of the Trophy, the identification sheets provided by the Manufacturer, as well as any comparisons, made by the Stewards in charge, with details provided by the Promoter and of which the same certifies conformity.
- S21.4) The checks will be carried out by the Technical Commissioners in the presence of the competitor or the mechanical assistant indicated in the



self-certification form.

If the competitor requires the assistance of a trainer/engineer during the check, the latter may access the Parc fermé only with the authorization of a Technical Commissioner and only for the time necessary for the check.

- S21.5) The Stewards, at any time and at their discretion, may arrange for the temporary or permanent replacement of the entire vehicle or parts of it with other parts, of which the Manufacturer certifies conformity (without expenses for the competitor). The Technical Commissioners have the right to keep the vehicle in the Parc fermé for the entire duration of the event.

In case of permanent replacement, the replaced parts will become the property of the Manufacturer and the competitor will no longer have the right to request their return.

- S21.6) Failure to bring the karts to the Parc fermé and/or taking them out early without permission will be considered as refusing the checks and will result in measures decided by the Stewards.
- S21.7) In the event that the check is destructive (prior to a written request of the technical delegate and authorization of the Stewards), the replacement of the damaged part with a new one will be guaranteed.
- S21.8) Any irregularities found in the checks will result in sanctions and measures based on the provisions of the Stewards within the limits set out by the International Sporting Regulations. The disciplinary sanctions will be established by the bodies arranged by the ATCE ASN in accordance with the provisions of the Specific Karting Sporting Regulations.

Art. S22) Protests and Appeals

- S22.1) Competitors have the right to protest against any decision, action, or conduct that they believe contravenes the regulations governing the championship. This includes but is not limited to, protests regarding race results, technical compliance, driving conduct, and procedural errors. Protests must be submitted in writing to the Clerk of the Course. The protest must include a detailed description of the incident, the specific regulation(s) alleged to have been violated, and any supporting evidence (e.g., witness statements, video footage). The protest must be signed by the competitor or their authorized representative.

A non-refundable **fee of EGP 2000** must accompany each protest and the window for the protest is only 10 Minutes after the session finishes.



Art. S23) Rankings and scores

- S23.1) In the EasyKart 60, EasyKart 100, EasyKart 125, BMB Challenge and TM kart Challenge, an overall ranking will be drawn up for all participants.
- S23.2) In all races of the Trophy, the same system will be respected for the attribution of scores. These scores are attributed according to two criteria. The first concerns a scale of points awarded from the first to the fifteenth place according to the table below:

PLACE	1st	2nd	3rd	4th	5th	6th	7th	8th	9th	10th	11th	12th	13th	14th	15th
SCORE	25	20	16	13	11	10	9	8	7	6	5	4	3	2	1

The second will be determined by the degree of difficulty of the race. The difficulty of one race compared to another will be determined by the number of participants in the race itself. Since it is more difficult to score points in a race with many participants than in a race with only a few, an additional score (called the "race difficulty coefficient") will be attributed to all the ranked participants. The first place will get an additional score of as many points as there are participants in the race, the second place will get the same points minus one, the third place will get the same points minus two and so on until the last place, who will therefore get only one point.

- S23.3) In the last round of the Trophy (see calendar attached to the regulations) double scores will be assigned as in the table below (including extra points assigned for pole position, sprint race and fastest lap):

PLACE	1st	2nd	3rd	4th	5th	6th	7th	8th	9th	10th	11th	12th	13th	14th	15th
SCORE	50	40	32	26	22	20	18	16	14	12	10	8	6	4	2

It should be noted that the attribution of the "participant coefficient" score remains the same as in the other races of the Trophy.

- S23.4) In the 2nd round in Arish, ten (10) "participation bonus" points will be awarded to all verified participants in addition to those assigned as participation coefficient.
- S23.5) The driver who has the fastest lap in the final will be awarded 1 point.
- S23.6) The sprint race will have the following points: 3 points winner, 2 points 2nd, 1 point 3rd. In the case of more than one sprint race, the points will be assigned for each single sprint race.
- S23.7) In the case a race is stopped and has not done 75% of the total race distance, points will be given half of the full race distance points.
- S23.8) For drivers who participate (verified) in all six (6) races of the Egyptian Trophy, an additional score of fifteen (15) points will be assigned for the final classification of the Trophy.
- S23.9) In the event of an equal, the highest number of victories during the



Trophy races will be considered. In the event of a further tie, the highest number of events in which the driver participated will be considered. In the event of further equality, the highest number of best places will be considered (second place, third place,...).

S23.10) The final rankings will determine the drivers admitted to the International Grand Final for each category.

Art. S24) International Grand Final

S24.1) The International Grand Final will include a single event. The event will be scheduled over two or more days. The EasyKart 60 Academy, EasyKart 60 U10, EasyKart 60, EasyKart 100, EasyKart 125, BMB Challenge & TM KART Challenge R1 – R2 categories will be allowed to participate (included EasyKart 125 Senior and TM KART Challenge R1 Master subcategories).

S24.2) According to the Trophy rankings, the number of drivers of Egyptian nationality who will be entitled to participate in the International Grand Final is as indicated in Art. 26.

Art. S25) Advertising

S25.1) The Promoter reserves the right to make use of the advertising space on the number board of each kart both to promote its own brands and to be allocated to any sponsors of the Trophy.

S25.2) It is forbidden for all competitors in all categories to display brands in contrast with the institutional ones of the Promoter (EasyKart, Birelart, Freeline, BMB, TM KART, etc.) on their kart and race clothing in the context of all EasyKart events, including the awards ceremony. It is also forbidden to display promotional material of any unauthorized nature in the paddock and other areas of the track during reserved EasyKart races.

Art. S26) Awards

S26.1) In each race of the EasyKart Trophy there will be awards for each final ranking, according to the provisions of the Specific Race Regulations.

S26.2) Awards will be given to: the top 3 in the EasyKart 60, EasyKart 100, EasyKart 125 Senior, BMB Challenge and TM KART Challenge. All awards must be collected strictly during the award ceremony in the podium area. Any exceptions will be granted by the promoter upon notice by the winners.

S26.3) In the case of an event with more than one final, awards will also be given to the first three (3) places in each final (A-B-C etc.), regardless of whether the same drivers have acquired the right to participate in a final of a higher degree.

S26.4) 3 awards will be granted for the winners from all categories of EasyKart and will qualify for the International Grand Final. However, if only two



categories are competing, two racers will be selected from the category with the higher number of participants, along with one racer from the other category, to ensure balanced representation.

- S26.5) The awards for the winners from each category of BMB Challenge and TM Challenge will qualify for the International Grand Final.
- S26.6) The Specific Regulations for each event may provide for additional awards.
- S26.7) A category is entitled to compete for an award only if a minimum of 5 participants complete in at least 3 rounds.

Art. S27) Other provisions

- S27.1) Access to the Parc fermé is allowed only and exclusively to the driver, with his own kart and his authorized mechanical assistant.
- S27.2) Access to the starting grid closes 5 minutes before the starting time, with no exceptions.
- S27.3) Any Damaged spare parts must be replaced to be eligible to enter the race. e.g. bumper, stickers, etc.



EasyKart TECHNICAL REGULATIONS

100cc – 125cc – 2025

Art. T1) General technical regulations

- T1.1) In the EasyKart 60/100/125 categories, it is strictly forbidden to bring or remove material, or carry out treatments that alter the mechanical characteristics and/or aesthetic appearance of the components if not allowed by the following regulations; all parts must be strictly as originally supplied.
- T1.2) Anything not expressly authorized by these Regulations is strictly forbidden. The kart must comply with these regulations for the entire duration of the event.
- T1.3) For anything not expressly stated in these technical Regulations, reference will be made to the Specific Karting Sporting Regulations.
- T1.4) On the occasion of each race, the Promoter of Egypt has the right to appoint its own specialized technicians as support consultants to the Technical Scrutineers for the checks of EasyKart engines and chassis. It should be noted that the consultants will be in possession of a valid "mechanical assistant" accreditation certificate.

Art. T2) Chassis

- T2.1) **Chassis:** only the Birelart chassis listed below are allowed, as well as standard products and assembled exclusively with originally mounted parts, except for the accessories permitted by these Regulations.
The mod. R30C-Y and L28C-Y chassis with the "U" shaped steering column support (1) can no longer be used for official EasyKart 2025 and subsequent events. The chassis compliant with the 2025 technical regulations will be the current ones with the mod. "iron" steering column support (2)

CATEGORY	60	100	125
Model	L28C-Y	R30C-Y	R30C-Y

①

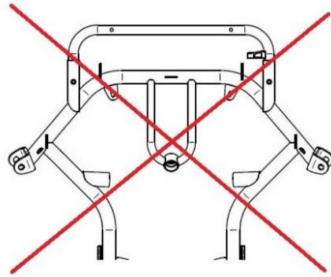

FRAMES NOT COMPLIANT WITH THE 2025 TECHNICAL REGULATION

②

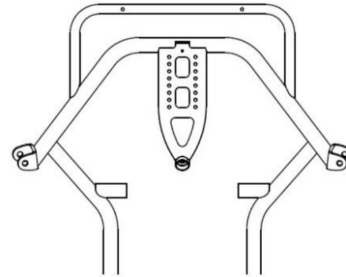

FRAMES COMPLIANT WITH THE 2025 TECHNICAL REGULATION

It should be noted that it will no longer be possible to use L28C-X and R30C-X frames.

T2.2) **Wheel track:** the maximum overall wheel track allowed is as shown in the table below.

CATEGORY	60	100	125
Pitch	900 mm	1,040 mm	1,040 mm
Maximum front track	970 mm	1,170 mm	1,170 mm
Maximum rear track	1,100 mm	1,400 mm	1,400 mm

For the category EasyKart 60 the overall rear width with rain tires cannot be less than 1080mm.

T2.3) **Floor:** it is mandatory to use the standard floor as supplied by the factory.

T2.4) **Pedals:** the pedals must be the standard ones, made of steel or FREELINE aluminum. The accelerator pedal must be fitted with a return spring. Between the brake pedal and the brake system pump, there must be an additional safety cable, correctly fastened. It is possible to adjust the position of the pedals using appropriate adjustable spacers and pedalboards, provided that the safety of the system is not compromised and that they are of the FREELINE brand.

T2.5) **Spindles:** The spindles must be strictly the standard ones. The wheel spacers must be original, 100/125 categories, it does not matter if mounted internally or externally. For categories EK100/125, if you can use the new spindles 10x165, you must use n. 3 spacers of 10mm and N. 3 of 5mm.



The use of the original factory eccentric bushings is allowed to modify the chassis caster and camber, mounted inside the "C" of the chassis.

CATEGORY	60	100	125
Spindles	10 x 135 E/17	10 x 165 E/17	10 x 165 E/17
	COD. 10.13413.00	COD. 10.12451.00	COD. 10.12451.00
	RH	RH	RH
	COD. 10.13414.00	COD. 10.12452.00	COD. 10.12452.00
	LH	LH	LH

- T2.6) **Front stabilizer:** the front stabilizer mounted on EasyKart 100/125 must be strictly the standard one. It is possible to remove the stabilizer to change the kart setup.
- T2.7) **Steering:** the steering control must be strictly the standard one, i.e. it consists of a steering column and rods, as originally mounted. All steering elements must have a safety fastening system (self-locking nuts). The steering wheel can be of any type and size as long as it is from the FREELINE range.

CATEGORY	60	100	125
Steering column	L 420	L 490	L 490
Standard steering wheel	Al. 320 Birel ART	Al. 320 Birel ART	Al. 320 Birel ART
HQ Aluminum steering rods	215 - 215	255 - 255	255 - 255

For safety reasons, the retaining ring under the nylon support of the steering column is mandatory as originally mounted.

- T2.8) **Tank:** the tank must be the standard one, in its original position. No replacements are allowed. The connecting pipes must be exclusively from the FREELINE range.

CATEGORY	60	100	125
Tank	4 Litres FL 4 Litres extr. KG	8 Litres FL 8 Litres KG	8 Litres FL 8 Litres KG



- T2.9) **Seat:** of any brand and model. Kevlar and carbon seats are prohibited. Additional supports are prohibited in the EasyKart 60 Academy and EasyKart 60 categories. In the EasyKart 100 and 125 categories, there must be two and they must be original FREELINE ones. Regardless of their length, they must be secured, one by one, from the bearing support boxes to the seat.
- T2.10) **Axle:** the axle must be a single piece (solid or perforated) of magnetic material, as originally mounted. In the EasyKart 125 category, the use of original FREELINE axles with housings for 4 or 5 keys is allowed.

CATEGORY	60	100	125
Axle	25 x 960 C	40 x 1040 x 3 M	40 x 1040 x 3 M
Axle weight	3.63 Kg	2.77 Kg	2.77 Kg
Rear hubs*	Al 25 x 50 HQ original black colour -cod. 10.10198.00-NE	Al 40 x 100 HQ original black colour - cod. 10.6944.00-NE	Al 40 x 100 HQ original black colour - cod. 10.6944.00-NE
Sprocket holder*	Al 25 – 6 A HQ original black colour -cod. 10.10320.00-NE	Al 40 – 6 A HQ original black colour - cod. 10.14755.00-NE	Al 40 – 6 A HQ original black colour - cod. 10.14755.00-NE
Bearing holder flange*	Al 30 HQ Original black colour -cod. 10.6432.00-NE	Al 40 HQ original black colour - cod. 10.6104.00-NE	Al 40 HQ original black colour - cod. 10.6104.00-NE

*Please note that old models with different designs, coloured codes can no longer be used, even if they are of the same size.



T2.11) **Brake system:** the brake system must be strictly the standard one, as originally mounted, as well as the brake pads which must be of the FREELINE range. During the check, the photographic identification card and any compliant samples provided by the Manufacturer will be valid.

CATEGORY	60	100	125
Rear brake system*	REAR BRAKE SYSTEM R-I25 H5/P22-SRLSI 370 Original black caliper and master cylinder cod. 10.11249.00	REAR BRAKE SYSTEM R-I38 H8/P22-SRLSI 510 Original black caliper and master cylinder Cod. 10.11250.00	REAR BRAKE SYSTEM R-I38 H8/P22-SRLSI 510 Original black caliper and master cylinder Cod. 10.11250.00
Rear brake disc	66 x 166 x 5 A	W 66 x 180 x 8A	W 66 x 180 x 8A
Rear disc holder*	FIXED DISC HOLDER C 25x80-6A HQ Original black colour Cod. 10.10319.00-NE	FIXED DISC HOLDER 40x66-8A HQ Original black colour Cod. 10.7189.00-NE	FIXED DISC HOLDER 40x66-8A HQ Original black colour Cod. 10.7189.00-NE
Rear brake pads	40 x 38 Grey/Black/Synt	56 x 15 FDB3	56 x 15 FDB3

*Please note that old models with different designs, colours and codes can no longer be used, even if they are of the same size.

T2.12) **Rims:** the rims must be exclusively the original ones mounted as standard, the fastening must involve a safety system (self-locking nuts).

	CATEGORY	60	100	125
S L I C K	Front rim*	5" CR 115A-NE Original black colour Cod. 10.14977.00-NE-SF	5" CH 130-LU Original glossy gray colour cod. 10.14972.00-LU	5" CH 130-LU Original glossy gray colour cod. 10.14972.00-LU
	Rear rim*	5" DR 150A- OR/NE Original black colour cod. 10.14980.00-NE-SF	5" DH 210-LU Original glossy gray colour cod. 10.14975.00-LU	5" DH 210-LU Original glossy gray colour cod. 10.14975.00-LU
	CATEGORY	60	100	125
R A I N	Front rim*	5" CR 115A-NE Original black colour Cod. 10.14977.00-NE-SF	5" CH 130-LU Original glossy gray colour cod. 10.14972.00-LU	5" CH 130-LU Original glossy gray colour cod. 10.14972.00-LU
	Rear rim*	5" DR 150A OR/NE Original black colour cod. 10.14980.00-NE-SF	5" DH 180-LU Original glossy gray colour cod. 10.14976.00-LU	5" DH 180-LU Original glossy gray colour cod. 10.14976.00-LU



KEY: the acronym **NE** identifies the colour **BLACK**, the acronym **LU** identifies a GLOSSY finish.

*Please note that old models with different designs, colours and codes can no longer be used, even if they are of the same size.

T2.13) **Front bumpers:** only the bumpers mounted as standard are allowed. The bumper fastening system must remain as originally mounted. Any additional supports or anchoring systems (nylon straps, steel cables or other) are prohibited.

CATEGORY	100cc	125cc
Front bumper	550 x 320/340 KG FP7	550 x 320/340 KG FP7

T2.14) **Pods:** only the pods mounted as standard are allowed; no modification or removal of material is allowed, with the exception of the hole for the insertion of the emergency starter.

CATEGORY	60	100	125
Front pod	KG MK14 KG MK20	KG507 KG509	KG507 KG509
Font panel	KG MK14 KG MK20	KG508 KG509	KG508 KG509
Side pods	FL 09/14 FL EVO MINI	FL EVO FL Areo	FL EVO FL Areo
Rear pod	FL 09/14 MINI	FL 09/14	FL 09/14

*You can use only without the deflectors

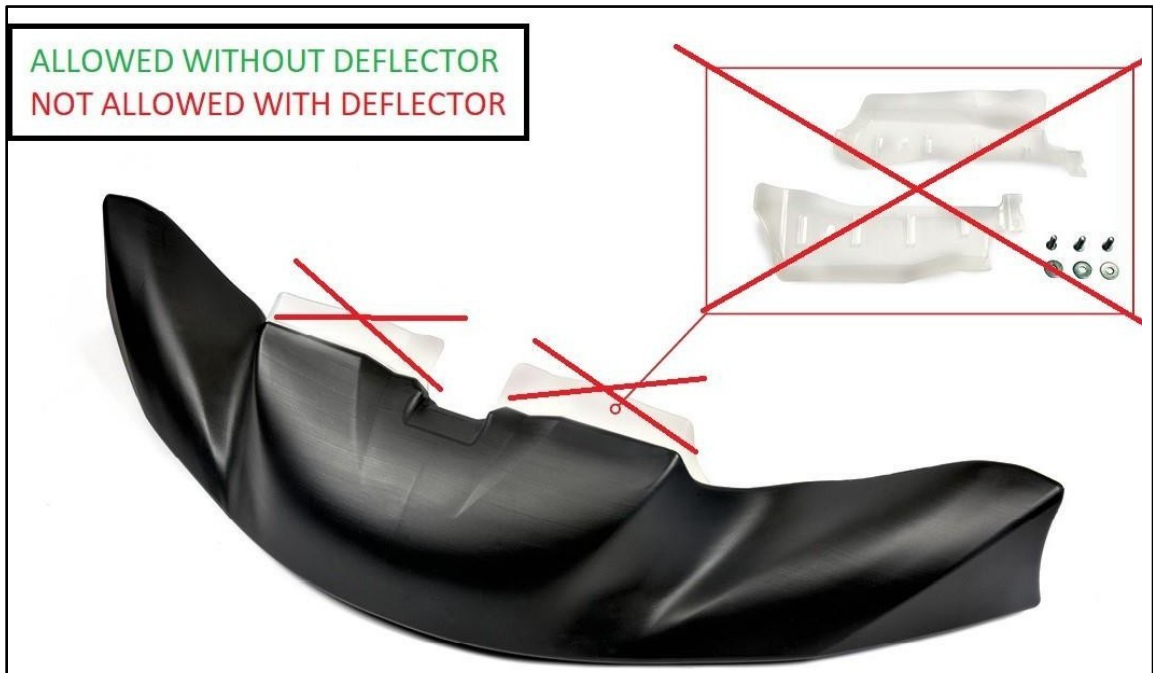

The fastening system of the front fairing must be the original one without any modification; the plates to be used are of the KG type, model KMS WITH ID NUMBER 1/CA/20- 01/01/ET.

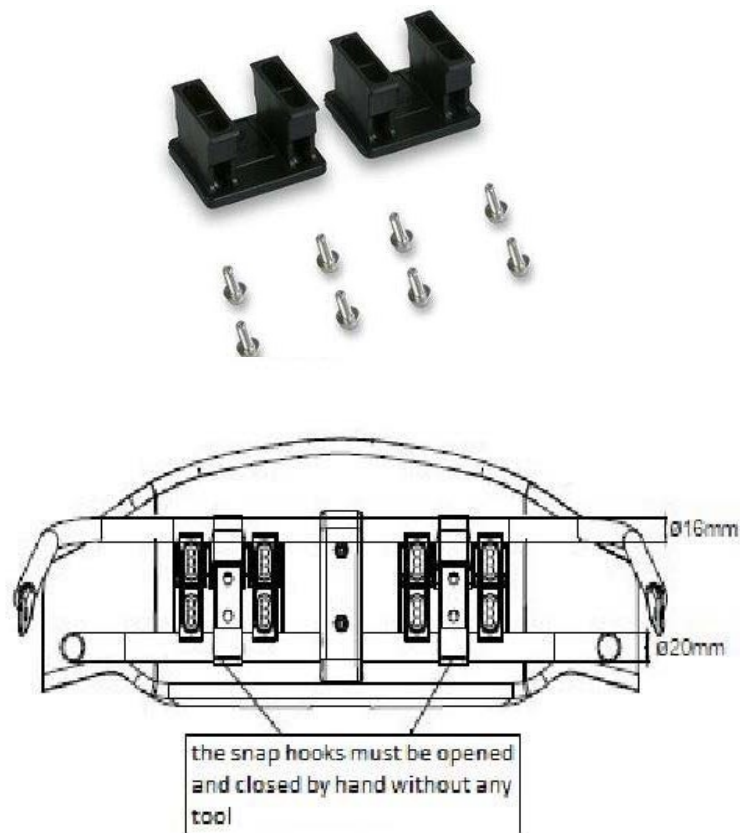

The front fairing must be able to move freely towards the chassis, without any obstacle limiting its movement

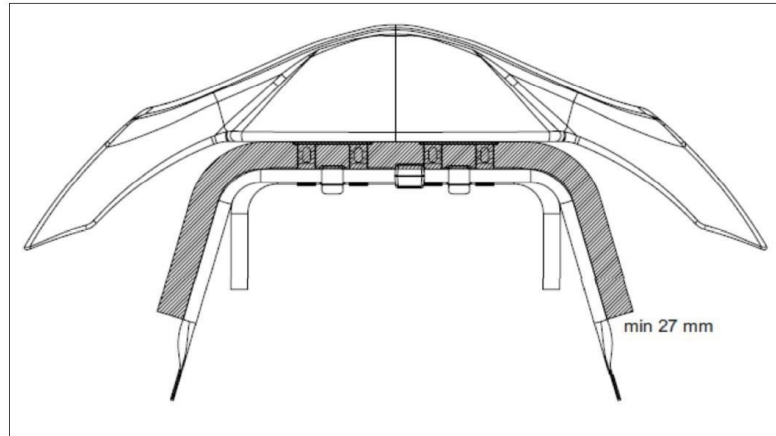
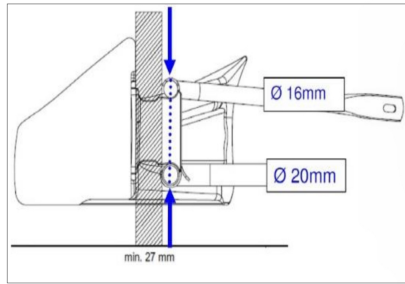

TECHNICAL DRAWING No. 2.2.1

Correct installation of the "Front Fairing" - Groups 1 & 2

Position acceptable / Acceptable position

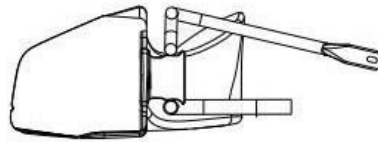

Not acceptable position if any part of the tubes of the front bumper are in the marked areas (A).

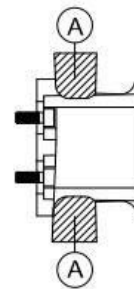
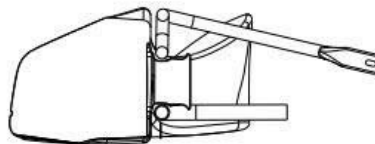
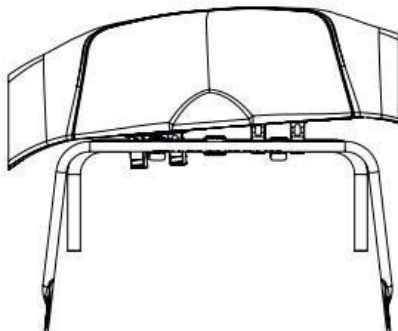



T2.15) **Race number:** each chassis must be equipped with four yellow number boards, one on the front, one on the back and one on each side (right and left). The race number stickers must be the black ones from the FREELINE range.

T2.16) **Optional accessories allowed:**

CATEGORY	60	100	125
Floor	With sticker	With sticker	With sticker
Bead breaker screw kit	-----	FREELINE HQ	FREELINE HQ
Wheel spacer kits	FL Aluminum HQ	FL Aluminum HQ	FL Aluminum HQ
Footrest	Shaped footrest	Shaped footrest	Shaped footrest
Inclined steering wheel supp. + inclined shim	FREELINE HQ	FREELINE HQ	FREELINE HQ
Eccentric bushings	0.5 and/or 1.5	0.5 and/or 1.5	0.5 and/or 1.5
Spindle	-----	Spindle assembly right 10x150-E/17/32 BIRELART Cod. 10.12317.00 Spindle assembly left 10x150-E/17/32 BIRELART Cod. 10.12318.00	Spindle assembly right 10x150-E/17/32 BIRELART Cod. 10.12317.00 Spindle assembly left 10x150-E/17/32 BIRELART Cod. 10.12318.00
Steering wheel	Al. 340 Birel ART	Al. 340 Birel ART	Al. 340 Birel ART

Art. T3) Engine

T3.1) **Engine:** the engines must be the original factory ones, of the BMB brand for the EasyKart 60/100/125 categories, they must also comply with their identification cards (plates). The external shape cannot be modified and must comply with the photos shown on them. No modification is allowed unless expressly authorized by the promoter. No type of polishing, removal or addition of material is allowed, and no



treatments that alter the mechanical characteristics and/or aesthetic appearance of the parts are allowed. All components must be the ones originally supplied. The only removal allowed is the grinding of the cylinder up to the maximum allowed size.

CATEGORIES	60	100	125cc
BMB	EKL	EKJ	EKA
Engine size	62cc	100cc	125cc
Stroke	43.3	48.5 mm	54 mm
Bore	42.68	51.12mm	54.28 mm

- a) The specifications can be found on the engine identification plates.
- b) The tolerances shown on the plates are to be understood as processing tolerances. The comparisons on the hardnesses of the various parts will be carried out with samples certified by the Manufacturer using an MITECH durometer mod. KH320
- c) The engine plate must be the one originally mounted as shown on the identification card (plate); both the removal and the addition of material are prohibited.
- d) It is the faculty of the scrutineers to seal the engine or its components during the entire event

T3.2) **Carburetor:** for the category EasyKart 100 only original factory carburetors are allowed; no modification or polishing of the inlet hole and venturi is allowed.

Only the fixed jets may be replaced, as indicated in the table. All jets must be original factory ones.

For the 60 categories, only the original factory black anodized carburetor is permitted, with a max. 19 mm venturi diffuser, verifiable with a "does not go" swab. The "power jet" system is not permitted.

For the EasyKart 100 category, only the original factory blue anodized carburetor is permitted, with a max. 24 mm venturi diffuser, verifiable with a "does not go" swab. The "power jet" system is not permitted.

For the EasyKart 125 category, only the original factory series carburetor is permitted, with a max. 26 mm venturi diffuser, verifiable with a "does not go" swab. The "power jet" system is not permitted.



T3.3) **Clutch:** the clutch must be strictly the original factory one; no modification is allowed. It is forbidden to oil or grease its components.

In the event of non-compliance due to the presence of lubricants, the Stewards' decision will be unquestionable.

CATEGORY	60	100cc	125cc
BMB clutch	EKL	EKJ - EKA	EKJ - EKA

T3.4) **Ignition:** the ignition must be strictly the original factory one; no modification is allowed.

CATEGORY	60	100	125
Ignition	SELETTTRA EL/S - limited 16,000 rpm	SELETTTRA EL/S -limited 16,000 rpm	SELETTTRA EL/S -limited 16,000 rpm

T3.5) **Spark plug:** for EasyKart 60/100/125 categories, there is only one spark plug and it must be of the brand NGK and be the original factory one; the thread length must not exceed 19 mm. The final edge of the head-mounted spark plug must not enter the combustion chamber in any way.

T3.6) **Inlet silencer:** it must be the one mounted originally, from the FREELINE range. Modification of the intake ducts is not allowed. The direction of assembly of the rubber fitting makes no difference; the excess part inside the silencer can be removed. The inlet silencer can be fastened with a nylon clamp to the main pipe without altering its operation. Any other fastening system is prohibited. The silencer must be fastened outside the carburetor. It is forbidden to fasten it inside.

CATEGORY	60	100	125
Inlet silencer	AL 22 PS	AL 22 PS	AL 22 PS

T3.7) **Suction filter:** only suction filters of the Freeline brand, model BR23R code 10.7203.00-RO and model KG NITRO 23 CIK-FIA homologated, are allowed.



T3.8) **Exhaust silencer:** only the exhaust manifold and the original silencer must be used; no modification or tampering is allowed.

It is possible to optimize the size of the flexible connection between the manifold and the muffler, provided that the same material and shape remain.

CATEGORY	100cc	125cc
Exhaust silencer	EKJ - EKA	EKJ - EKA

For safety reasons, the exhaust silencer must be connected to the exhaust manifold by a steel cable closed with a double-fixing clamp.

T3.9) **Tools:** the use of a data acquisition tool (timing, rev counter, odometer, GPS, and spark plug temperature and exhaust) is allowed; anything not specified is strictly forbidden.

Art. T4) Fuel

T4.1) For the EasyKart 60/100/125 categories, the Fuel must consist of a mixture of commercial unleaded petrol, purchased from kart Riders distributor and 2T KART Motul oil, with a ratio of 20 liters of petrol and a bottle of oil. The Stewards may authorize the replacement of the entire contents of the tank with fuel indicated by the organizer. The checks will be carried out using a DIGATRON DT47 device.

In the event of non-compliance, the Stewards' decision will be unquestionable.

CATEGORY	60	100cc	125cc
Petrol/Oil ratio	20 / 1	20 / 1	20 / 1

Art. T5) Transmission

T5.1) The transmission between the engine and the axle must take place by means of a closed chain. The crowns must be exclusively from the FREELINE range. For the EasyKart 60/100/125 categories, the ratio must be indicated by the Organizer and displayed on the official competition notice board before each event and chosen from the range shown in the table

CATEGORY	60	100cc	125cc
Pinion	Z10	Z10-Z11-Z12	Z10-Z11-Z12
Crown	79-80-83-84	78-80-81-82--86	78-80-82-85
Chain	100-102-104	102-104-106	102-104-106

- ❖ To facilitate technical checks, the crown must be mounted with the identification numbers towards the inside.

T5.2) **Chain guard:** for the EasyKart 60/100/125 categories, it is mandatory to mount the closed chain guard of the FREELINE brand, as originally mounted. It is forbidden to alter the shapes and/or add holes except for the one necessary for ignition by means of an "emergency" starter (see S15.2 of the Sporting Regulations).

Art. T6) Tyres

T6.1) **Tyres:** only EasyKart tyres produced by Vega are allowed, as shown in the tables below, both SLICK and RAIN. For the latter, no further patterns or touch-ups are allowed compared to the original tread.

S L I C K	CATEGORY	60	100	125
	Front	ETS 10x4.00-5	ETS 10x4.60-5	ETS 10x4.60-5
	Rear	ETS 11x5.00-5	ETS 11x7.10-5	ETS 11x7.10-5
R A I N	CATEGORY	60	100	125
	Front	ETR 10x4.00-5	ETR 10x4.00-5	ETR 10x4.00-5
	Rear	ETR 11x5.00-5	ETR 11x6.00-5	ETR 11x6.00-5

T6.2) Treatments that alter the characteristics and/or performance of the tyres themselves are strictly prohibited (see the Specific Karting Sporting



Regulations in force).

The checks will be carried out by comparison using a RAE SYSTEMS device mod. MiniRAE 3000.

In the event of non-compliance, the Stewards' decision will be unquestionable.

Art. T7) WEIGHT

T7.1) **Overall weight:** the minimum weight is measured with the kart in running order and with the driver on board dressed for a race, in the conditions in which the finish line is crossed. Any ballast must be mounted exclusively and securely with at least two fastening points (2 x 8 mm screws), with the exception of the bumpers and floor, using screws and relative self-locking nuts. Lead shots, or other non-solid material are not allowed

CATEGORY	60	100	125
Weight of kart + driver	110 kg	140 kg	160 kg

Validity: These Technical and Sporting Regulations shall be valid for one (1) year.



TECHNICAL REGULATIONS BMB CHALLENGE 2025

Art. T1) GENERAL RULES

- T1.1) It is strictly forbidden to remove material.
- T1.2) The kart must comply with these regulations for the entire duration of the event.
- T1.3) For anything not expressly indicated in these Technical-Sporting Regulations, and on the identification cards of the engines and chassis, reference will be made to the 2024 National Technical and Sporting Regulations and to the CIK-FIA Regulations.

Art. T2) Chassis

- T2.1) **Frame:** all frames of any brand and model are allowed, with valid or expired CIK-FIA approval, equipped with accessories and safety systems, as per the provisions of the National Technical Regulations in force.
- T2.2) **Wheel Track:** the maximum permitted wheel track width is 1,400 mm overall.
- T2.3) **Rims:** The maximum permitted width of the front rims is 135 mm. The maximum permitted width of the rear rims is 215 mm.
- T2.4) **Front fairings:** all fairings with valid and previous CIK-FIA approval with release system are allowed; refer to the provisions of the Specific Karting Technical Regulations in force. Lateral fairings: all fairings with valid and previous CIK-FIA approval are allowed. Rear fairings: all fairings with valid and previous CIK-FIA approval are allowed.
- T2.5) **Brake systems:** all brake systems with valid and previous CIK-FIA approval are allowed. The use of front brakes is not allowed.

Art. T3) Engine

- T3.1) **Engine:** only BMB HAT EL/S engines may be used, complying with the type-approval certificates in force and published on the website www.easkart.it.

The external shape cannot be modified and must comply with the photos shown on them, as well as any comparisons with samples provided by the Manufacturer.

It is the faculty of the scrutineers to seal the engine or its components



during the entire event.

- T3.2) **Spark plug:** the following types of spark plug can be used: BMB/BRISK L8S - BMB/BRISK L10SL - NGK B9 EG - NGK B10 EG - NGK BR10EIX - NGK BR9EIX
- T3.3) **Carburettor:** only the following carburettors may be used:
Tryton mod. HB27
Only the standard carburettor, the original factory one, with venturi diffuser max 26 mm, verifiable with "pass / fail" buffer is allowed. The "power jet" system is not allowed.
- T3.4) **Suction filter:** only suction filters of the Freeline brand, model BR23R code 10.7203.00- RO and model KG NITRO 23 CIK-FIA homologated, are allowed.
- T3.5) **Transmission:** free.
- T3.6) **Radiator:** radiators of any brand and model are allowed; the use of antifreeze fluids is prohibited.

Art. T4) Fuel

- T4.1) **Fuel:** it must consist of a mixture of commercial unleaded petrol, purchased from the race distributor indicated by the organisation and 2-stroke oil of any brand and percentage, with valid CIK-FIA approval, to be indicated in the self-certification form presented during the sporting checks. For fuel checks, see the National Technical Regulations for the karting sector in force. The checks will be carried out using a DIGATRON DT47 device.

In the event of non-compliance, the Stewards' decision will be unquestionable.

Art. T5) Tyres

- T5.1) **Tyres:** only KPG/EasyKart tyres produced by Vega S.r.l. are allowed, shown in the tables below, both SLICK and RAIN. For the latter, no further patterns or touch-ups are allowed compared to the original tread.

S L I C K	CATEGORY	BMB Challenge
	Front	KPG 10x4.60-5
	Rear	KPG11x7.10-5
R A I N	CATEGORY	BMB Challenge
	Front	ETR 10x4.00-5
	Rear	ETR 11x6.00-5



Art. T6) WEIGHT

T6.1) **OVERALL WEIGHT:** the minimum overall weight is measured with the kart in running order and with the driver on board dressed for a race, in the conditions in which the finish line is crossed. Any ballast must be mounted exclusively and securely with at least two fastening points (2 x 8 mm screws), with the exception of the bumpers and floor, using screws and relative self-locking nuts. Lead shots, or other non-solid material are not allowed.

CATEGORY	BMB Challenge
Weight of kart + driver	155 kg



TECHNICAL REGULATIONS TM KART CHALLENGE 2025

Art. T1) General rules

- T1.1) It is strictly forbidden to remove material.
- T1.2) The kart must comply with these regulations for the entire duration of the event.
- T1.3) For anything not expressly indicated in these Technical-Sporting Regulations, and on the identification cards of the engines and chassis, reference will be made to the 2024 National Technical and Sporting Regulations and to the CIK-FIA Regulations.

Art. T2) Chassis

- T2.1) **Frame:** all frames of any brand and model are allowed, with valid or expired CIK-FIA approval, equipped with accessories and safety systems, as per the provisions of the National Technical Regulations in force.
- T2.2) **Wheel Track:** the maximum permitted wheel track width is 1,400 mm overall.
- T2.3) **Rims:** The maximum permitted width of the front rims is 135 mm. The maximum permitted width of the rear rims is 215 mm.
- T2.4) **Front fairings:** all fairings with valid and previous CIK-FIA approval with release system are allowed; refer to the provisions of the Specific Karting Technical Regulations in force. Lateral fairings: all fairings with valid and previous CIK-FIA approval are allowed. Rear fairings: all fairings with valid and previous CIK-FIA approval are allowed.
- T2.5) **Brake systems:** all brake systems with valid and previous CIK-FIA approval are allowed.

Art. T3) Engine

- T3.1) **Engine:** only TM KART engines may be used, complying with the type-approval certificates in force and published on the website www.easkart.it.

The external shape cannot be modified and must comply with the photos shown on them, as well as any comparisons with samples provided by the Manufacturer.

It is the faculty of the scrutineers to seal the engine or its components during the entire event.

It is mandatory to use Conrod & Piston with original TM logo as the photo below:



- T3.2) **Exhaust silencer:** sono all brands of silencers are allowed from the have current or old homologation CIK-FIA in corso di validità.
- T3.3) **Transmission:** free
- T3.4) **Gearbox:** must be as homologation fiche and with mechanical change. Exception for drivers with license Fisaps it is allowed an electromechanical gear change system.
- T3.5) **Radiator:** radiators of any brand and model are allowed; the use of antifreeze fluid is prohibited.

Art. T4) Fuel

- T4.1) **Fuel:** it must consist of a mixture of commercial unleaded petrol, purchased from the race distributor indicated by the organisation and 2-stroke oil of any brand and percentage, with valid CIK-FIA approval, to be indicated in the self-certification form presented during the sporting checks. For fuel checks, see the National Technical Regulations for the karting sector in force. The checks will be carried out using a DIGATRON DT47 device. 29



In the event of non-compliance, the Stewards' decision will be unquestionable.

Art. T5) Tyres

T5.1) **Tyres:** only KPG/EasyKart tyres produced by Vega S.r.l. are allowed, shown in the tables below, both SLICK and RAIN. For the latter, no further patterns or touch-ups are allowed compared to the original tread.

S L I C K	CATEGORY	TM Kart Challenge
	Front	KPG 10x4.60-5
	Rear	KPG11x7.10-5
R A I N	CATEGORY	TM Kart Challenge
	Front	ETR 10x4.00-5
	Rear	ETR 11x6.00-5

Art. T6) WEIGHT

T6.1) **OVERALL WEIGHT:** the minimum overall weight is measured with the kart in running order and with the driver on board dressed for a race, in the conditions in which the finish line is crossed. Any ballast must be mounted exclusively and securely with at least two fastening points (2 x 8 mm screws), with the exception of the bumpers and floor, using screws and relative self-locking nuts. Lead shots, or other non-solid material are not allowed.

CATEGORY	TM Kart Challenge
Weight of kart + driver	175 kg



Appendix

Art. G1) APPENDIX 1-CALENDAR 2025

Date	Race	Track	Ratio				
			EK60	EK100	EK125	BMB Challenge	TM Kart Challenge
19/4/2025	Round 1	CK RSTC	11/79	10/80	11/80	Free	Free
3/5/2025	Round 2	CK Arish	10/84	10/86	10/85	Free	Free
28/6/2025	Round 3	One Eleven	10/79	11/82	11/82	Free	Free
26/7/2025	Round 4	One Eleven Rev	10/79	11/82	11/82	Free	Free
16/8/2025	Round 5	One Eleven	10/80	11/82	11/82	Free	Free
6/9/2025	Round 6	TBC	11/83	11/82	11/82	Free	Free

It should be noted that the ratios to be used are subject to possible changes by the promoter upon prior notice.

Art. G2) APPENDIX 2 - Flags & Boards

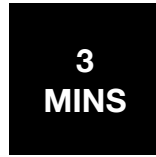
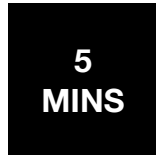
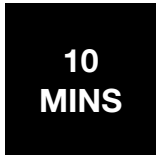

COUNT DOWN BOARDS TO THE START OF THE RACE

FLAG SIGNALS



NATIONAL FLAG or LIGHT SIGNALS
Start of the race

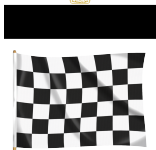

BLACK AND WHITE CHECKERED FLAG
Finish of the race, practice or qualifying session



RED FLAG
Racing must stop immediately. All drivers to return to the start/finish line at a reduced speed. The pit lane is closed



BLUE FLAG
A faster driver is attempting to overtake – move over

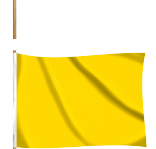

YELLOW FLAG
indicates danger ahead, slow down, no overtaking. Waved or double yellow flag – great caution.

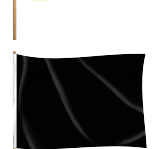

BLACK FLAG WITH RACE NUMBER
Indicates disqualification from the race. The offending driver must immediately return to the pits and report to race officials.

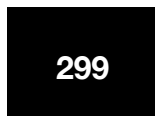
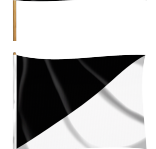

BLACK AND WHITE DIAGONAL FLAG WITH RACE NUMBER
Warning of unsportsmanlike conduct. A repeat may result in the driver receiving a time penalty or disqualification.



BLACK FLAG WITH ORANGE DISC AND RACE NUMBER
Indicates that there is a mechanical problem and the kart is in need of immediate repair.



RED AND YELLOW STRIPED FLAG
Slippery surface ahead.



GREEN FLAG
A previous incident is clear and normal racing can resume.



BOARDS SIGNALS

Final Lap

One lap remaining to race or practice finish

Contact

Contact with another kart during a race or practice

Track Limit

Striking or crossing a kerb track edge mark



Art. G3) APPENDIX 3 -Pricing and Detail

- G3.1) Each race weekend consists of several cost components, and drivers can either rent a kart from the organizers or bring their own Race Costs for Non-Owners (Per Round)
- **Kart Rental:** EGP 20,000 (for rental drivers only)
 - **Race Registration:** EGP 10,000
 - **Free Trail:** EGP 2,000 per day (includes up to 6 practice sessions, fuel not included)
 - **Mechanic Fee:** EGP 1,500 (optional, must be verified by Kart Riders if bringing their own)
 - **Tent Rental:** EGP 1,000
 - **Engine Rental:** EGP 10,000 per round (Kart owners can rent an engine as a spare for this price.)
- G3.2) For Round 6, the race fee **does not** include accommodation.
- G3.3) Tyre & Fuel Information
- Racing Tyres Cost: EGP 15,568.94 per round
 - Fuel: Available for purchase from the Parc ferme at price EGP 20 per litter.
- G3.4) Full Season Packages
- Rental Full Package (Kart Rented from Promoter): EGP 306,000
 - Owner's Full Package (Driver Brings Own Kart): EGP 230,000
- These packages include all costs (kart/engine rental if applicable, race registration, Free Trial for 2 days, Fuel, mechanic, and tent rental).

	Kart Rent	Engine Rent	Free Trial Fees	Mechanic Hiring	Tent Rent	Race Tyres	Registration Fees
Round 1	20,000	10,000	2,000	1,500	1,000	15,568.94	10,000
Round 2	20,000	10,000	2,000	1,500	1,000	15,568.94	25,000
Round 3	20,000	10,000	2,000	1,500	1,000	15,568.94	20,000
Round 4	20,000	10,000	2,000	1,500	1,000	15,568.94	20,000
Round 5	20,000	10,000	2,000	1,500	1,000	15,568.94	20,000
Round 6	20,000	10,000	2,000	1,500	1,000	15,568.94	30,000